

H23/25 TPX

Telescopic
boom

- +70° / -70° fly jib.
- Standard 4 wheel drive.
- 550 lb (250 kg) platform capacity.
- 14 in (34 cm) ground clearance.



ISO 9001
GROUP
PINGUELY
HAULOTTE



ARTICULATED BOOMS



VERTICAL MASTS



TELESCOPIC BOOMS



SCISSOR LIFTS



TRAILERS

Haulotte®

ON THE UP

H23/25 TPX

The Haulotte® advantages

- Improved working area through a positive / negative articulating fly jib with 140° movement
- Hydraulic differential lock and 14 in (34 cm) ground clearance for improved rough terrain capability
- Continuous 360° turntable rotation
- 180° hydraulic platform rotation
- Compact travel/transport dimensions
- Full proportional controls and simultaneous boom functions improve productivity
- Work platform overload limiter increases safety
- Robust, reliable and easy to maintain design

STANDARD FEATURES

- Silent pack Hatz Diesel engine
- 4 wheel drive
- 5° tilt alarm
- 24 V electrical control system
- 12 V - 95 AH - battery
- Free wheeling device
- Electric emergency lowering system
- Safe use in winds up to 37 mph (60 km/h)
- Hourmeter
- Turret slewing lock rod
- Towing hooks / lifting eyes
- 2 hooks for safety harness in platform

OPTIONS & ACCESSORIES

- Large platform H 23 TPX (2.3 m x 0.8 m / 7 ft 6 in x 2 ft 7 in)
- 220 V / 16 A power line to platform
- Rotating beacon
- Flashing light
- Travel alarm
- Catalytic exhaust
- Hostile environment kit
- Sandblast protection kit
- Encoded starting device



TELESCOPIC BOOM

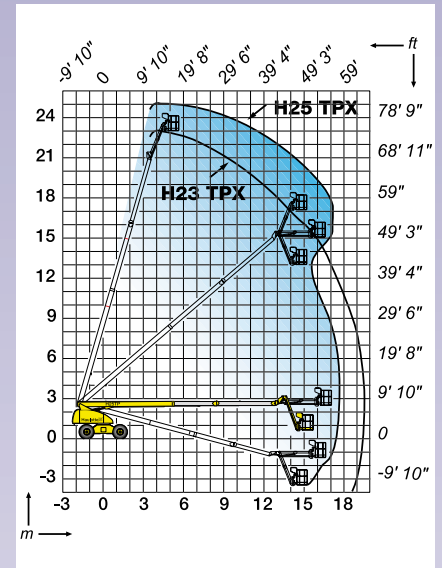
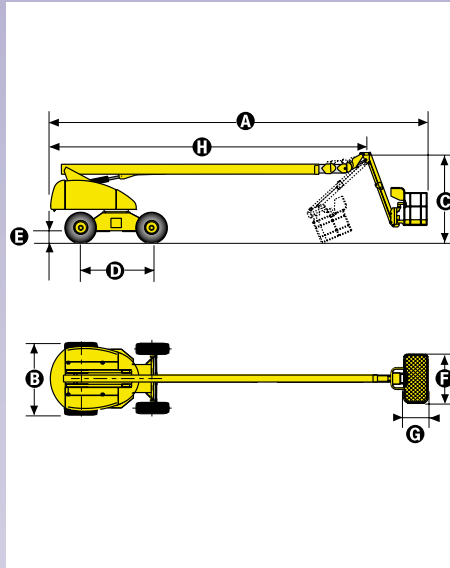

SPECIFICATIONS

	H23TPX		H25TPX	
Working height	74 ft	22.6 m	82 ft	25 m
Platform height	68 ft	20.6 m	76 ft	23 m
Horizontal outreach	64 ft	19.5 m	58 ft	17.5 m
Platform capacity	550 lb	250 kg	550 lb	250 kg
Fly jib range of motion	140° (+70°/-70°)		140° (+70°/-70°)	
Jib length	7 ft 2 in	2.2 m	7 ft 2 in	2.2 m
A Length	36 ft 2 in	11.05 m	42 ft 2 in	12.87 m
B Width	8 ft 1 in	2.47 m	8 ft 2 in	2.48 m
C Stowed height	9 ft 3 in	2.84 m	10 ft	3.10 m
D Wheelbase	8 ft 1 in	2.49 m	8 ft 1 in	2.49 m
E Ground clearance	14 in	34 cm	14 in	34 cm
F x G Platform size	71 in x 32 in	1.8 m x 0.8 m	71 in x 32 in	1.8 m x 0.8 m
H Travel/transport length	33 ft 8 in	10.3 m	35 ft 4 in	10.8 m
Tailswing	3 ft 5 in	1.06 m	3 ft 5 in	1.06 m
Drive speed	3.1 mph	5 km/h	3.1 mph	5 km/h
Outside turning radius	20 ft 2 in	6.15 m	20 ft 2 in	6.15 m
Turntable rotation (continuous)	360°	360°	360°	360°
Hydraulic platform rotation	180°	180°	180°	180°
Gradeability	40%	40%	40%	40%
Engine	Diesel Hatz 3 L 41C - 53 hp - 38 kw			
Controls	proportional	proportional	proportional	proportional
Tyres (foam filled)	15 R 22.5 XF	15 R 22.5 XF	15 R 22.5 XF	15 R 22.5 XF
Hydraulic tank	33 gallons	150 l	33 gallons	150 l
Fuel tank	33 gallons	150 l	33 gallons	150 l
Weight	30,312 lb	13,750 kg	30,532 lb	13,850 kg

AS1418.10

